



 **SVAGO**<sup>TM</sup>

## **SV-630 Use and Care Manual**

V 1.0

Thank you for purchasing this Svago ZG-Recliner.  
To ensure that you don't overlook any of your chair's features, and that you use it safely, read this manual carefully. Then sit back, relax, and enjoy!

## **TABLE OF CONTENTS**

IMPORTANT SAFETY INSTRUCTIONS .....	1-2
CHAIR COMPONENTS .....	3
CHAIR SPECIFICATIONS .....	4
CHAIR DIMENSIONS .....	4-5
PLACING THE CHAIR .....	6
PREPARATIONS PRIOR TO USE .....	7
OPERATION GUIDE .....	8-11
MAINTENANCE PROCEDURES .....	12
TROUBLESHOOTING .....	13
WARRANTY INFORMATION .....	14-16
Warranty Card (Attachment)	



# IMPORTANT SAFETY INSTRUCTIONS

**When using an electrical appliance, basic precautions should always be followed, including the following:**

**DANGER: To reduce the risk of electrical shock,** always unplug Svago™ from the electrical outlet immediately after using and before cleaning.

**WARNING: To reduce the risk of burns, fire, electric shock or injury to persons:**

- Do not put hands or fingers near the footrest mechanism on the under side of the chair while this product is running. Touching the mechanism can result in injury.
- If the supply cord is damaged, it must be replaced by the manufacturer or its service agent or a similarly qualified person in order to avoid a hazard.
- An appliance should never be left unattended when plugged in. Unplug from outlet when not in use, and before putting on or taking of parts.
- Close supervision is necessary when this product is used by, on, or near children, invalids, or disabled persons. Keep children away from extended foot support (or other similar parts).
- Use this product only for its intended use as described in this manual. Do not use attachments not recommended by the manufacturer.
- Never operate this product if it has a damaged cord or plug, if it is not working properly, if it has been dropped or damaged, or dropped into water. Return this product to a service center for examination and repair.
- Do not carry this appliance by supply cord or use cord as a handle.
- Always keep the power cord away from heated surfaces.
- Never operate this product with the air openings blocked. Keep the air openings free of lint, hair, and the like.
- Never drop or insert any object into any opening.
- Do not use outdoors.
- Do not operate where aerosol (spray) products are being used or where oxygen is being administered.

- Do not use this product when standing on a damp floor, or when any part of the body is in contact with plumbing or any similar ground.
- Do not use this product if noise above normal sound is heard.
- Do not stand on or in appliance. Use only while seated.
- This appliance is not intended for use by persons (including children) with reduced physical, sensory or mental capabilities, or lack of experience and knowledge, unless they have been given supervision or instruction concerning use of the appliance by a person responsible for their safety.

Children should be supervised to ensure that they do not play with the appliance. Please consult your doctor if you have any doubts about using this chair or if you are pregnant, undergoing medical treatment, using a medical electronic device or are receiving oxygen.

- Comfortable clothing is recommended while using this product.
- If you feel any abnormal discomfort during the operation of this product, turn off the power immediately and do not use the product. Consult your physician.
- **Do not pull on the AC cord.**
- When using this product after it has been in storage, check to see that the product is operating properly prior to use.
- Always confirm that there are no obstacles behind the product and that there is sufficient space to recline.

- **Do not attempt to repair this product yourself.**

- This product is designed for personal in-home use.

Commercial use will void warranty.

- To reduce the risk of electric shock, this appliance has a polarized plug (one blade is wider than the other). This plug will fit in a polarized outlet only one way. If the plug does not fit fully in the outlet, reverse the plug. If it still does not fit, contact a qualified electrician to install the proper outlet. Do not change the plug in any way.



# CHAIR COMPONENTS

Check the accessories first

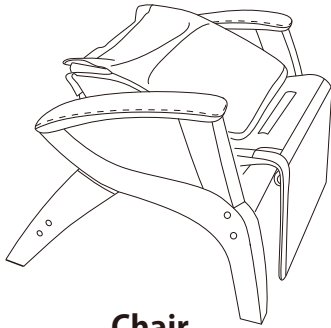

**Chair**

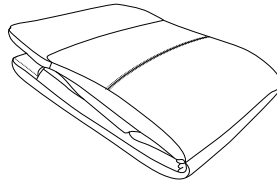

**Cushions**

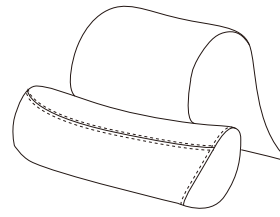

**Pillow**

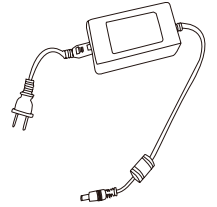

**Powercord**

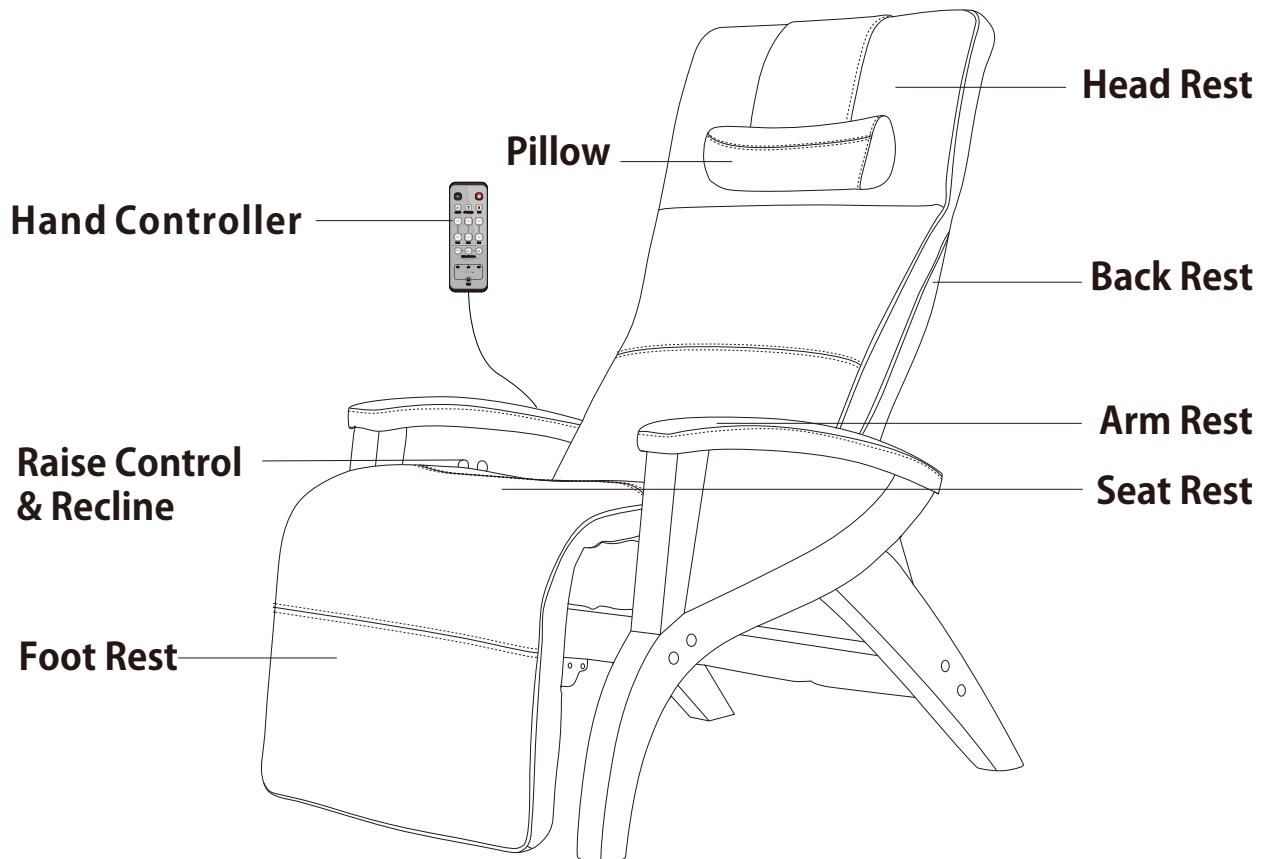

# CHAIR SPECIFICATIONS

Specifications	Description
Model No.	SV -630
Rated Voltage	Input 110-120V
Rated Frequency	60Hz
Out-put	24V DC 3A
Rated Power Consumption	72W
Auto Timer	15 minutes
Dimensions (L*W*H)	Chair Upright: 39.4"x30.3"x47.2"
	Chair Reclined: 62.2"x30.3"x33.1"
	Packing Carton: 45.3"x31.7"X25.6"

Specifications		Description
Weight	Net Weight	110 lbs
	Gross Weight	129 lbs
Maximum Load Weight		400 lbs
Required Recline Clearance		11.8"
Usage Condition		Environmental temperature 10°C-40°C Contrasting humidity level 30-85RH
Storage Condition		Storage temperature 20°C-55°C Storage humidity level 30-85RH
Safety Feature		Equipped with overheating and power surge detectors

# CHAIR DIMENSIONS

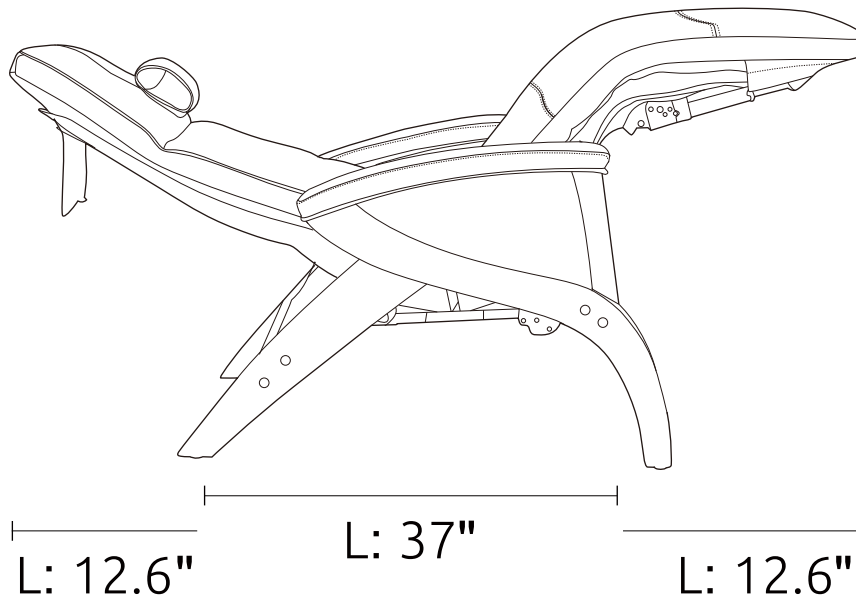

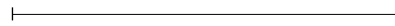
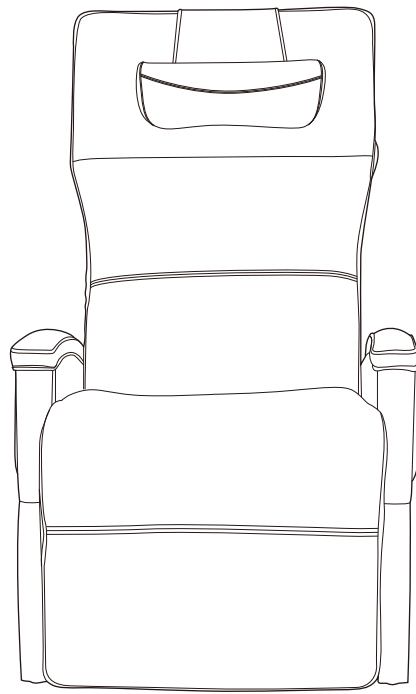

L: 30.3"

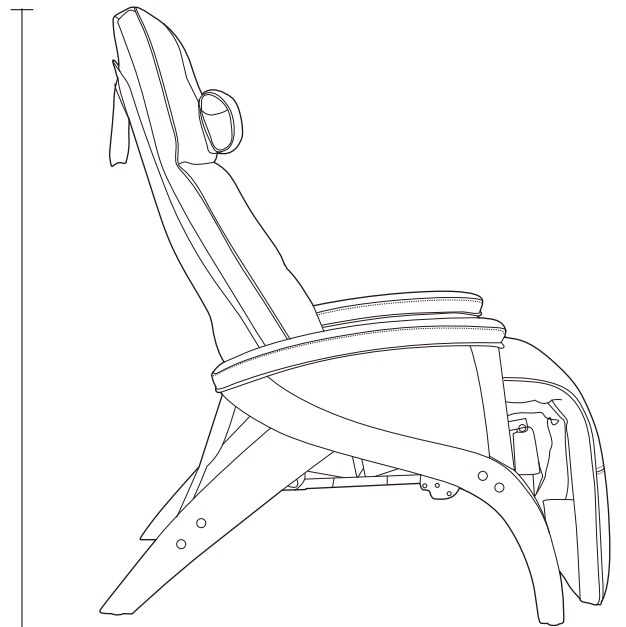

H: 47.2"



L: 39.4"

# PLACING THE CHAIR

1. Lay a carpet, etc. on the set-up place.

It prevents damaging the floor, and muffles the noise during use.

2. Ensure there is sufficient space to allow the chair to recline.

In order not to touch the wall or other things when reclined, allow a clearance of 30cm(11.8") or more to the front and the back of the chair.

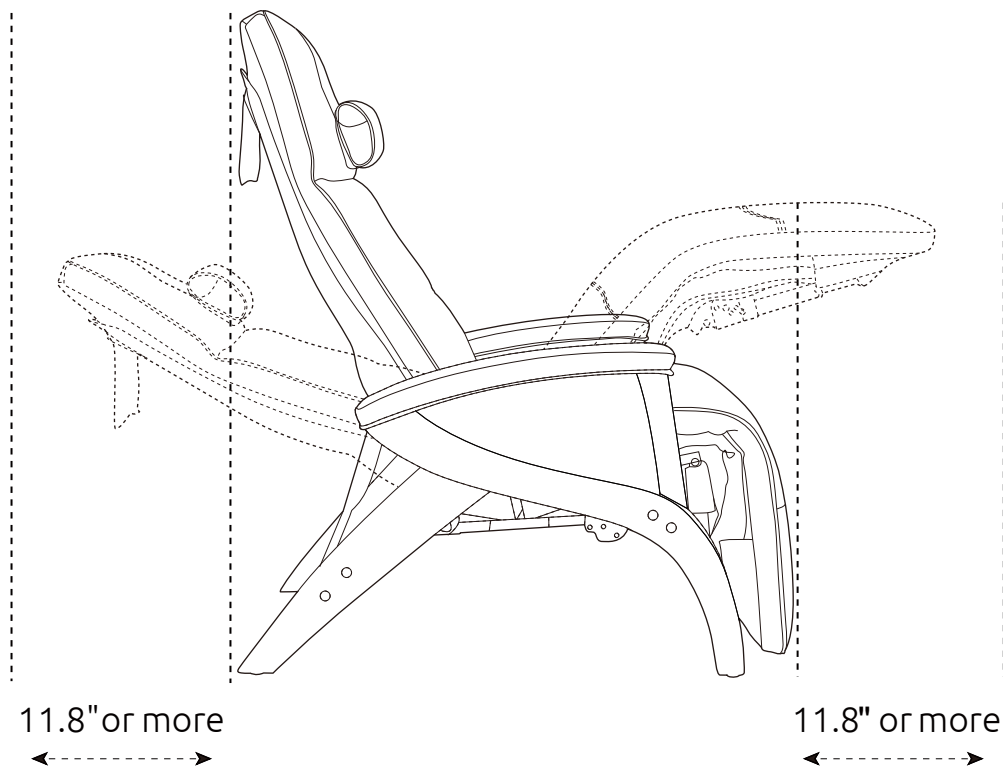

## Notes

- Place the chair on a level surface.
- Keep the chair at least 1 meter(3ft) away from AV machines like a TV or radio.
- Do not keep the chair in a place with high humidity like a bathroom.
- Do not keep the chair in a place where it will be exposed to direct sunshine for an extended period, or in a place near to a heater where the temperature may reach high levels.





# PREPARATIONS PRIOR TO USE

## 1. Check the cloth of the chair

Prior to use, be sure to check that the cover cloth and the cloth of other parts are not torn. If the chair has been torn anywhere, stop using the chair immediately, unplug the power source, and obtain service. This is to avoid any injury or electric shock.

## 2. Check the power cord

Check that there is neither breakage nor damage to the power adaptor. Check that the cords are not caught or placed beneath the chair.

## 3. How to connect the power source.

- 1) Connect the power adaptor with the chair.
- 2) Insert the power plug into an outlet.

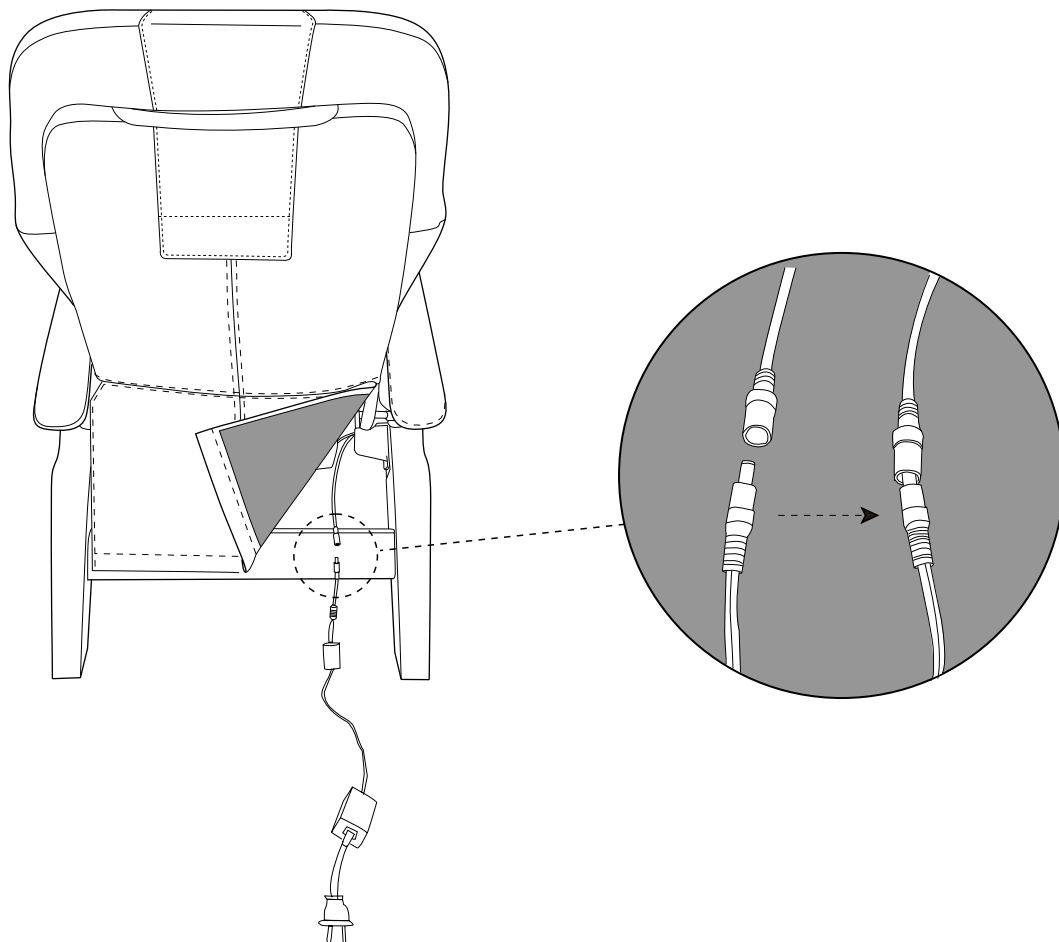

# OPERATION GUIDE

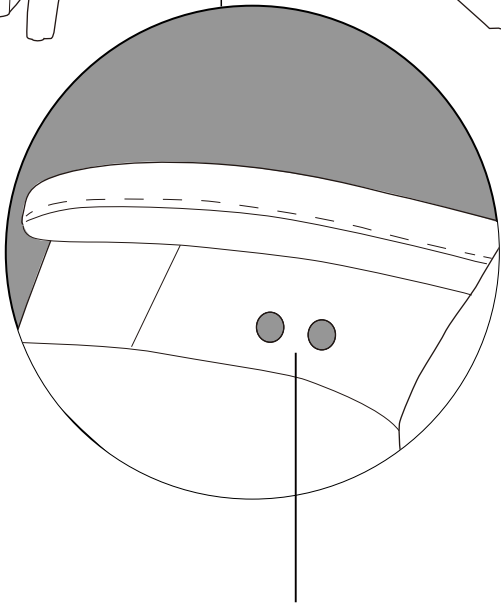
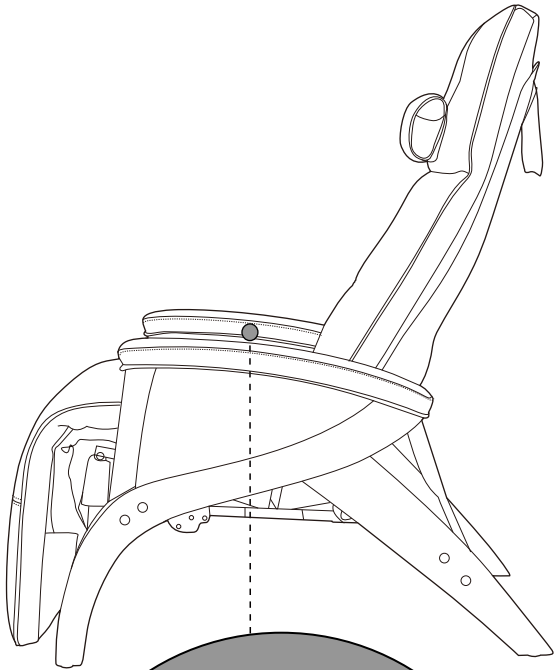

**Raise & Recline Control**

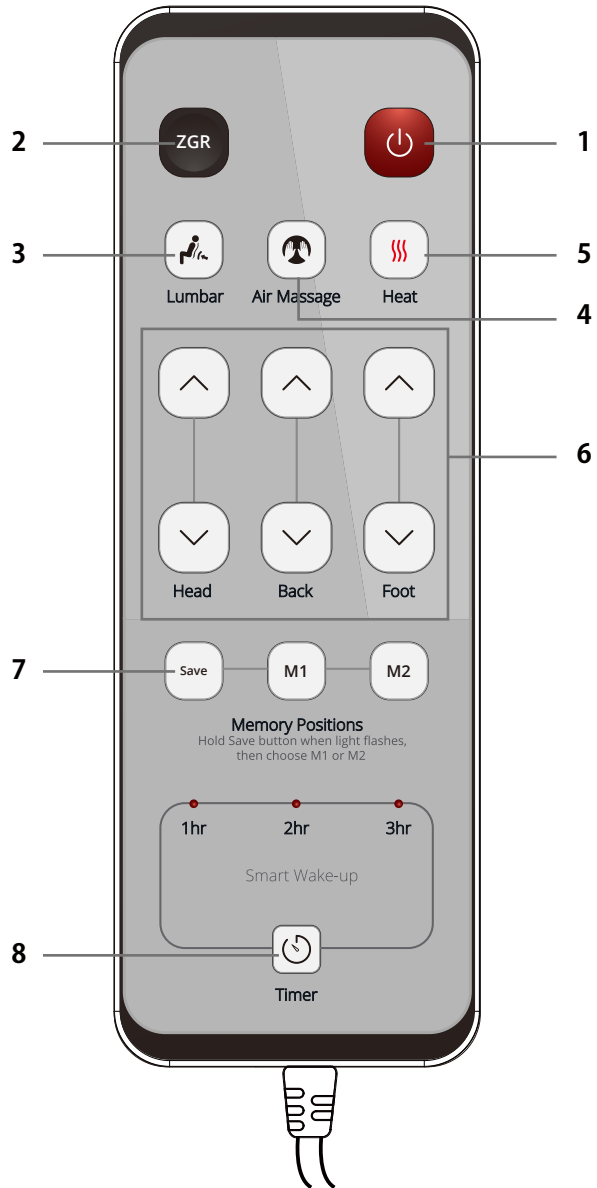

**Hand Controller**



## 1. On/Off

When you press the button, lamp of on/off and 6 arrows buttons illuminates, the chair is in idle, and will start to work when you press any other function buttons.

**When you want to suspend the operation or have some abnormality with your body, press On/Off button, operation stops and all the lamps extinguish.**

## 2. ZGR

When you press the button, the back rest, foot rest, and seat are automatically adjusted to prearranged ZG-Recliner reclining angles.

- Reclining motion can be paused by pressing either On/Off button or ZGR button; if On/Off button pressed, press again chair will restore to home position and be power-off; if ZGR button pressed, you still can press function buttons for desired motion.
- After achieving the ZGR position, you still may adjust back rest and foot rest angles by pressing the relevant buttons.

## 3. Lumbar Support

- Press Lumbar button to start its 15 seconds motion, press again to hold the desired support strength before this motion end, the third press will cancel the support gradually; if 15 seconds finished without holding, the second press is able to cancel the support gradually.
- Lumbar support will stop working if turn to press air massage button, and vice versa.
- Lumbar support will hold even though chair system Automatic Shut-off, press again or power off to close it.

#### 4. Air Massage

- Seven air bags are built into the chair and independently inflate and deflate in predetermined sequences. They stretch muscles to loosen tension with a soft massage that improves circulation and relieves body fatigue.
- Press Air Massage button to start the massage motion, press again to stop it.
- Air massage will pause during any reclining adjustments and resume automatically after adjustment.

#### 5. Heating

- Press Heat button to start heating back, press again to stop it.
- Heating cycle is 1 hour without cancel stop, this motion is independent operation to the 15 minutes automatic shut-off.
- Heating will pause during any reclining adjustments and resume automatically after adjustments.

#### 6. Upholstery Motion of Head, Back, Foot

- Press and hold relevant button to activate the motion, release the button when desired angle achieved.
- These buttons work even though On/Off button not open.

**NOTE:**

Be sure to check that there is nobody or any pets around the chair prior to adjust the back rest. It may result in accident or injury.



## 7. Memory Positions



- Press and hold Setup button for 3 seconds to get flashing M1/M2, press M1/M2 to confirm a new memory position has been set.
- Press M1/M2 button to achieve the memory position which has been set before.
- If you want quit during M1/M2 motion, press any of the arrow buttons to stop.

## 8. Smart Wake-up

- Press Timer button to start setting, press again to plus and minus the 1 to 6 hours option.
- When time is up, On/Off button is flashing, soft air massage program will proceed and get user back to home position, meanwhile all functions stop working.
- If you want to quit during time up program, press On/Off button to restore to the idle mode.

### Automatic Shut-off

- The Svago chair has 15 minutes automatic shut-off function. Air Massage stop after 15 minutes and can be reset by restarting On/Off button. Meanwhile, upholstery reclining and restore movement stop at existing position, restore to home position by restarting On/Off button.

### CAUTIONS - AFTER USE

- Bring the chair to its upright position.
- Turn off the power.
- If the chair is not used for an extended time, disconnect the power cord.

# MAINTENANCE PROCEDURE

## **WARNING**

Be sure to disconnect the power plug from the outlet prior to maintenance

## **NOTE**

Do not attempt to use benzene. Thinner alcohol ,alkaline detergent or bleaching agent for cleaning,as this may result in deformation, discoloration or cracking.

## **HEAD REST, BACK PAD, SEAT COVER, ARM REST, FOOT REST, PILLOW(LEATHER)**

Perform daily maintenance by wiping with a soft dry cloth. When parts are badly soiled, adopt the following maintenance procedure.

1. Use an eraser to wipe gently.

2. Wipe it with a dry cloth afterwards.

- When leather parts scratched, try to use finger pulp to appease first, then wipe it with a dry cloth afterwards.
- Do not force-dry with a drier.
- Do not force contact with vinyl products for an extended period. It may cause discoloration.

## **NOTES**

- Leather is a natural material, so imperfections grain, dye variations and natural markings do not constitute a defect.
- Polyurethane foam padding tends to soften and light creases may form on the leather cover over a period of three months. These are natural occurrences and do not require any type of maintenance.
- A professional cleaner should be contacted for particular types of stains such as ink marks.



# TROUBLESHOOTING

## WARNING

If the trouble still persists after following the proper countermeasures, stop using the chair to avoid possible accidents. Disconnect the power plug from the outlet and consult Svago service department. Do not attempt to repair the chair, instead contact a certified technician.

Type of Troubles	Check points	Countermeasures
<b>Operation failure</b>	Check that the power plug is securely plugged into the outlet.	Push the power plug into the outlet securely.
	Check that the power adaptor is well connected to the chair.	Well connect the DC terminals between the chair and power adaptor.
<b>The chair stops in the middle of operation.</b>	This phenomenon is caused by the timer, but not a problem.	
<b>Impossible to recline. Impossible to raise or lower the foot rest.</b>	Check that there is no obstruction.	Remove the obstruction.

If you continue to have problems, please read the warranty card and contact the Svago service department.

# WARRANTY INFORMATION

## **Svago products have the following warranty:**

Svago ZG-Recliner provide a one year in home servicing warranty and a two year parts warranty. Svago customer service will not issue Return Material Authorizations (RMAs) for products. In case of missing parts or service issues, please contact the Svago service department. Svago will not issue Return Material Authorizations (RMAs) to buyers.

## **SERVICE AND TECHNICAL SUPPORT**

- Consumers may contact Svago's Customer Service Department at 1-877-977-0656 between 10.00am and 6.00pm EST, Monday through Friday or email us at Service@cozziausa.com or visit our web site at www.svago.com for warrant and service issues.
- Consumers are required to provide the unit serial number and dated proof of purchase (sales receipt) when they contact the Svago service department regarding a repair.
- A Svago customer service representative will attend to most consumer inquiries but in some cases a technical service specialist will be required to provide enhanced support.
- Non warrant repair is provided on a 'per incident' basis. Svago customer service will verify that the unit has failed and provide instructions for repair. All applicable repairs, parts, shipping, handling, local tax and a 'per incident' fee will be charged for non-warranty repairs and support calls.
- Proof of purchase (original receipt) is required for all warranty repairs or servicing.





## **EXTENDED WARRANTIES**

- Svago offers extended warranty programs to enhance ownership of Svago products. Extended warranty provides a three year limited repair or replacement massage chair warranty with on-site service.
- Please visit [www.svago.com](http://www.svago.com) for the latest terms and pricing for extended warranties.

## **PRODUCT REPAIRS**

- Many Svago parts may be installed by the consumer in his/her own home with parts and instructions supplied by Svago ,such as remote controller replacements that do not require a technician.
- Floor Models and Demonstration Units have a pro-rated Warranty period that begins the day the model is placed on the floor and connected to an electrical outlet by the retail partner. Proof of purchase is required in order to obtain warranty service and parts. Non-warranty parts and service are available at a 'per incident' charge.
- Warranty Coverage Period: warranty coverage starts at the time the consumer purchases their chair. Proof of purchase is required for all warranty repairs. The warranty time period is measured by continuous calendar days based on the seven day week.
- Field Service: Svago Customer Service Department will diagnose and schedule an authorized service provider to repair the chair in the customer's residence.
- Parts: all parts deemed necessary for repairs will be shipped to the customer at no charge by the Svago Service Department.

## **CONSUMER WARRANTY LIMITATIONS AND EXCLUSIONS**

- Warranties are only valid in the 48 contiguous United States and Canada and are contingent upon the consumer operating the chair according to the corresponding instruction manual.
- The warranty only applies to Svago products and does not include any accessories or enhancements.

- Field service requires pre-approval and must be performed by Svago's authorized field service personnel. Field service is only available in the United States and major metropolitan areas in Canada.
- Softening of foam and filling composites in pillows, pads and memory foam occurs naturally and does not constitute a defect under this warranty.
- Fading, wear and piling of fabric occurs naturally and does not constitute a defect under this warranty.
- Natural markings, grain and dye variations in leather do not constitute a defect under this warranty.
- Warranties do not cover any loss or damage resulting from improper installation, unauthorized repairs or modifications, improper use of the electrical/power supply, loss of power, a dropped product, a malfunction or damage of an operating part due to failure to implement the manufacturer's recommended maintenance, transportation damage, theft, abuse, misuse, neglect, vandalism or environmental conditions (fire, floods, rust, corrosion, sand, dirt, windstorm, hail, earthquake or exposure to weather conditions). Loss of use during the period the product is at a repair facility or is otherwise awaiting parts or repair.
- Damage due to shipping and handling does not constitute a defect under this warranty.
- Under no circumstances shall Svago or its representatives be liable for indirect consequential or incidental damage (including damages for lost profits, business interruption, bodily injury, medical problems) even if the other party has been advised of the possibility of such damages or possible problems.
- Warranties are non-transferable and shall be in lieu of any other warranty express or implied, including but limited to any implied warranty or merchantability of fitness for particular use.
- Svago's sole liability and the purchaser's exclusive remedy shall be for repair, or at Svago's option, for the replacement of the defective part. Notwithstanding the above, if replacement parts for defective materials are not available, Svago reserves the right to make substitutions in lieu of repair or replacement.
- All warranties begin on the date of purchase, no allowance or extension is offered for delivery and/or installation.
- Warranties do not apply to rental, business, commercial, institutional or other nonresidential users.



**WARRANTY REGISTRATION FORM**

Product Serial No.(Located on product) \_\_\_\_\_

Purchase Price: \_\_\_\_\_ Model No: \_\_\_\_\_

Date Purchased: \_\_\_\_\_

First Name: \_\_\_\_\_ Last Name: \_\_\_\_\_

Address: \_\_\_\_\_

City: \_\_\_\_\_ State: \_\_\_\_\_ Zip Code: \_\_\_\_\_

Phone: \_\_\_\_\_

Email: \_\_\_\_\_

Please mail to:  
COZZIA USA LLC  
861 S. Oak Park Road,  
Covina, CA 91724  
TEL: 1-877-977-0656  
FAX: 1-800-521-4712



REDEFINING ZG-RECLINER